

Machining unmarked tolerances in accordance with ISO 2768-C	0.5	3	6	30	120	400	1000	2000	Welded structure without tolerance ISO 13920-B	2	30	120	400	1000	2000	Straightness and flatness without tolerance ISO 2768-L	0	10	30	100	300	1000	Verticality without tolerance ISO 2768-L	0	100	300	1000
	0.2	3	6	30	120	400	1000	2000		30	120	400	1000	2000	10		30	100	300	1000	100	300		1000	3000		
	±0.2	±0.3	±0.5	±0.8	±1.2	±2	±3	±4		±1	±2	±3	±4	±6	TOL		TOL	TOL	TOL	0.6	1	1.5		2			
	TOL	TOL	TOL	TOL	TOL	TOL	TOL	TOL		TOL	TOL	TOL	TOL	TOL	TOL		TOL	TOL	TOL	TOL	TOL	TOL		TOL			

4-M6x1  
Inlaid steel sleeve  
Hole depth 20, thread depth 16

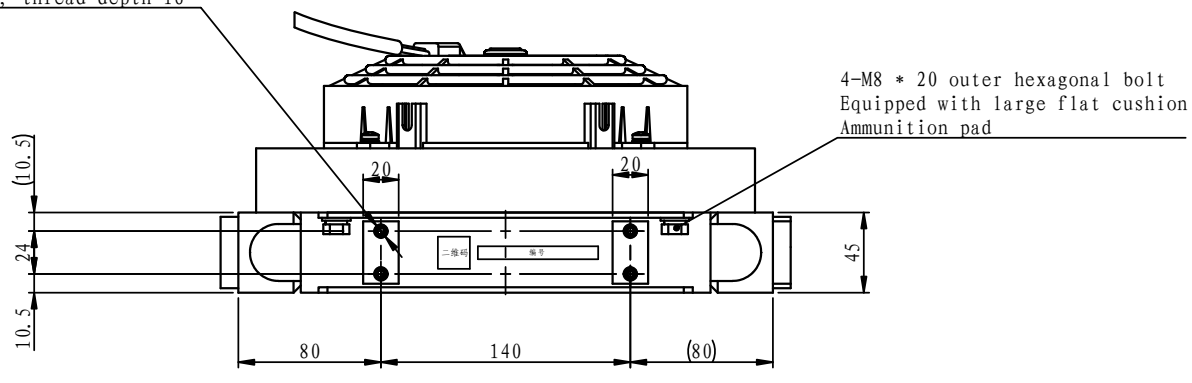

Working medium	oil	Holding time (min)	
Flow rate L/min			
Design pressure MPa	1.6		
Design pressure Mpa	strength	2.4	5
	Air tightness	1.76	5

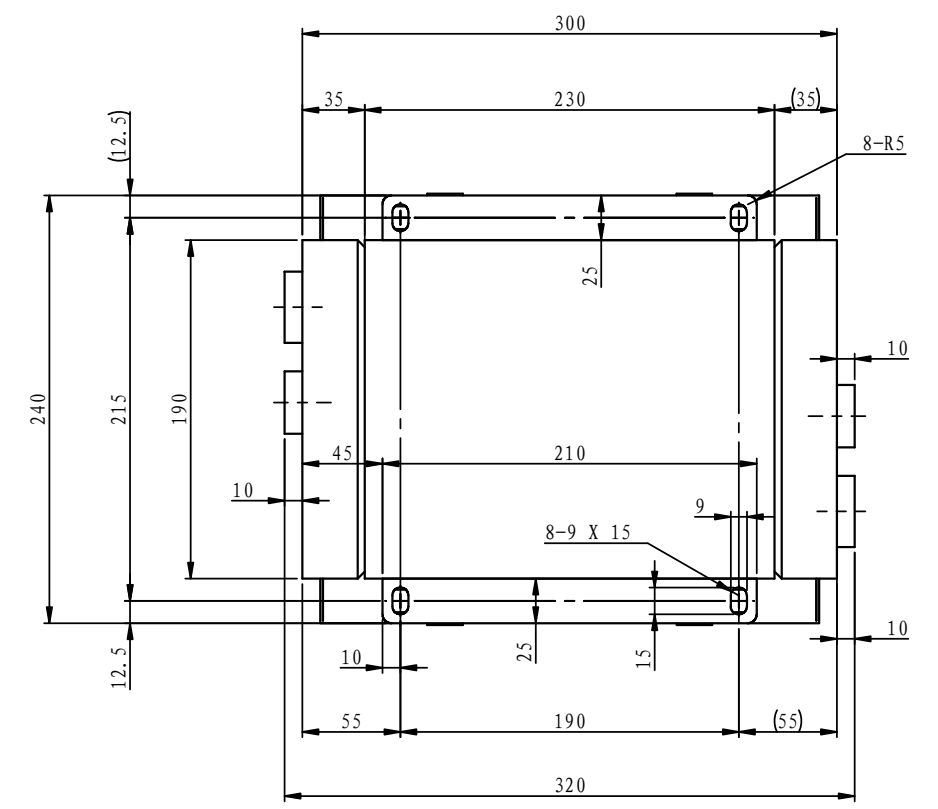
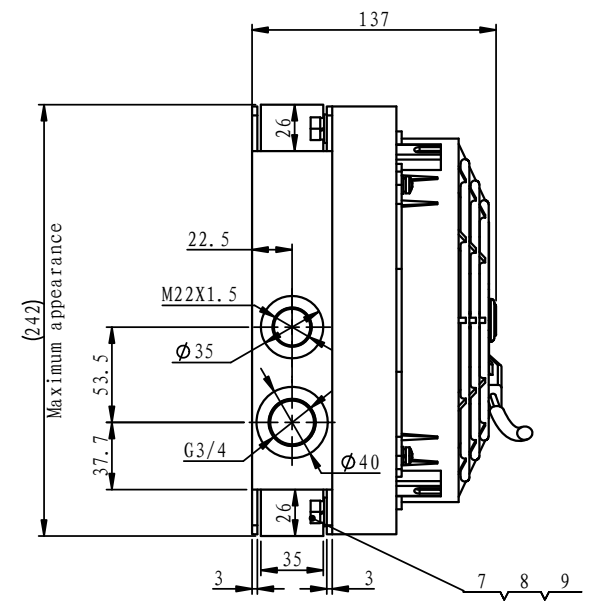
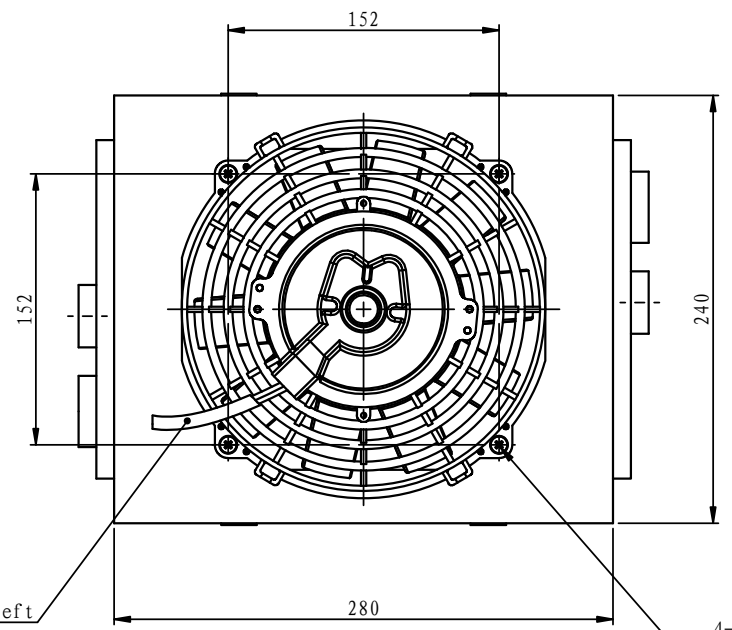
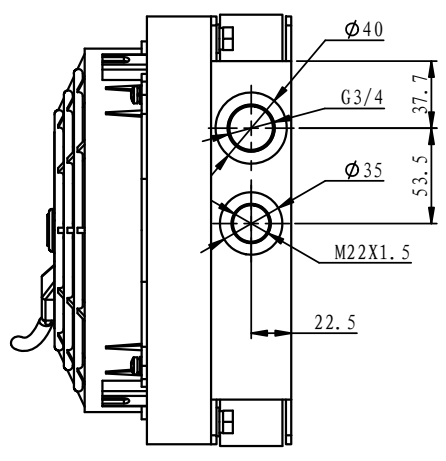

The motor wire is placed towards the bottom left

4-M5 \* 15 Cross recessed pan head screw  
Flat pad  
Ammunition pad

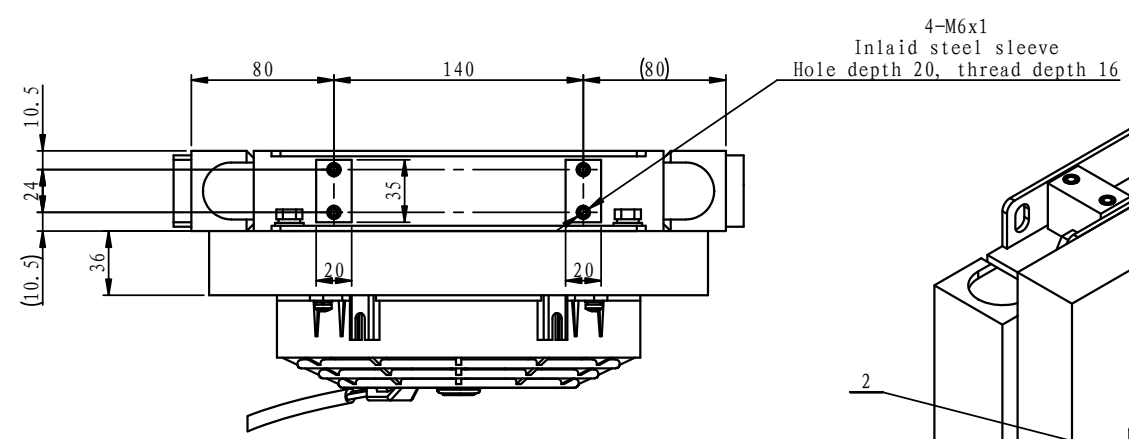

4-M6x1  
Inlaid steel sleeve  
Hole depth 20, thread depth 16

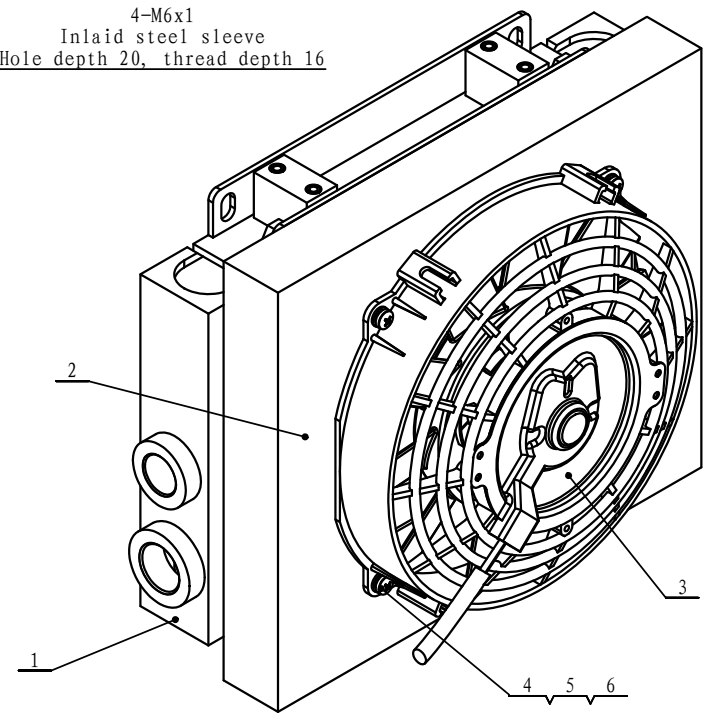

- Technical requirements;
1. Manufactured and accepted in accordance with NB/T47006-2009 "Aluminum Plate Fin Heat Exchangers".
  2. Argon arc welding must be fully welded, without gas seams or cracks, and the shape must be beautiful.
  3. The appearance must not have serious bumps or scratches, and the exposed welds must be repaired flat.
  4. Blow dry the interior, wipe off the exterior, and seal the pipe mouth
  5. Unmarked dimensional tolerances shall be executed according to GB/T1804-C level
  6. Radiator electrostatic spraying: black RAL9005
  7. Electrostatic spraying of sheet metal parts: black RAL9005

9	GB/T 95-1985	平垫	8	4	304	0.00	0	
8	GB/T 93-1987	弹垫	8	4	304	0.00	0	
7	GB/T5783-2000	外六角螺栓	M8 × 1.25, L=20	4	A2-70	0.01	0.04	
6	GB/T 95-1985	平垫	5	4	304	0.00	0	
5	GB/T 93-1987	弹垫	5	4	304	0.00	0	
4	GB/T 818-2016	十字槽盘头螺钉	M5, L=15	4	A2-70		0	
3	B64996ZC-02	风机	LNF-2190	1		0.65	0.65	
2	B64996ZC-01	导风罩		1	Q235	1.15	1.15	
1	B64996	油冷却器		1		3.14	3.14	
序号	代号	名称	规格	数量	材料	单重	总重	备注

				oil cooler assembly		B64996ZC		
				00		4.98	1:3	
				ST50		WuXi JiaLong Heatechanger Stock Company LTD		
MARK No.	REV.	SIGN	DATE					
Design	NIZHEN	Standard						
Draw		App/Ver						
Technics		DATE						